

BOOKLET B: [44 marks]

For questions 29 to 40, write your answers in the spaces provided. The number of marks available is shown in brackets [] at the end of each question or part-question.

29. The diagram below shows the direction of movement of substances A and B in a plant.

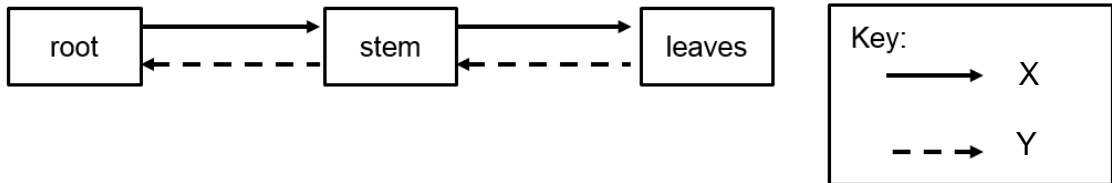

(a) Name the substances X and Y. [2]

Substance X: _____

Substance Y: _____

(b) Describe one way in which the human blood vessels differ from the transport tubes in plants. [1]

30. Devi put some plants into an air-tight glass container. She placed the container near the window.

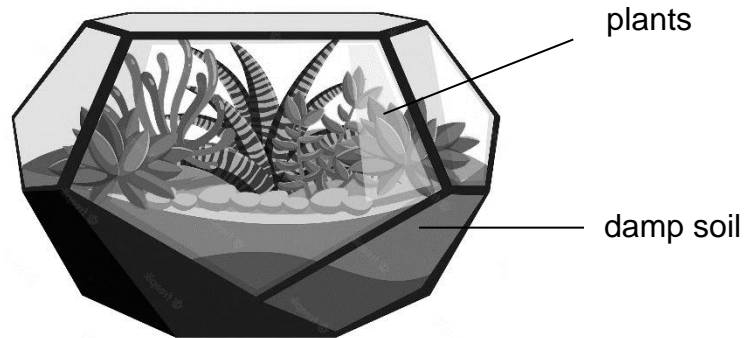

(a) After one day, some water droplets were observed on the inner surface of the glass container. Explain how the water droplets were formed. [2]

(b) After 2 weeks, Devi found that the plants were still alive in the container. Explain how the plants were able to get constant supply of air in the airtight glass container. [2]

31. Shanti wanted to find out if the temperature of water affects the amount of oxygen dissolved in water.

She placed four beakers of water in four different places in school in the morning, and came back a few hours later to measure the temperature of the water and the amount of oxygen in the water using a datalogger. Her results are recorded in the table below.

Location	Temperature (°C)	Amount of oxygen (units)
Fridge (chiller)	5	12
Fridge (main compartment)	15	10
Air-conditioned room	25	8
Classroom	30	7

(a) State one variable changed in this experiment. [1]

(b) Based on the table above, what is the relationship between the temperature of water and amount of oxygen dissolved in the water? [1]

The gills of a fish “beats” when it opens and closes to draw in water through its mouth and releases the water through its gills as shown below.

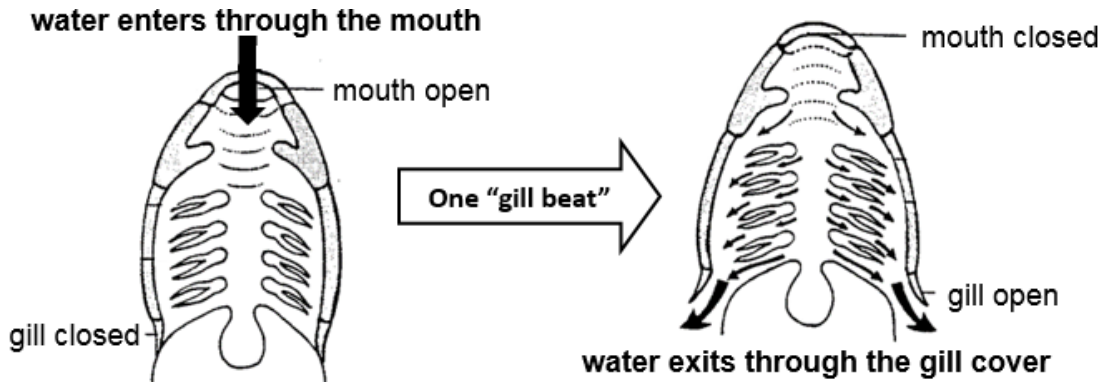

“Gill beat” rate in fish is similar to breathing rate in humans.

- (c) What will happen to the gill beat rate of fish in the pond during the hotter months of the year? Explain your answer.

[2]

32. Ant P and spider S are organisms that live in the same habitat. They have the same predators and eat the same food.

Ant P lives in large groups of thousands or more in one nest. They guard their nests with their painful bites. Therefore, predators often stay away from the nests and only prey on ants who wander far away.

Spider S is often found near the nests of ant P and is able to enter their nests without being attacked.

What are two advantages for spider S looking like ant P? [2]

Advantage 1: _____

Advantage 2: _____

33. Figure 1 shows a pond community.

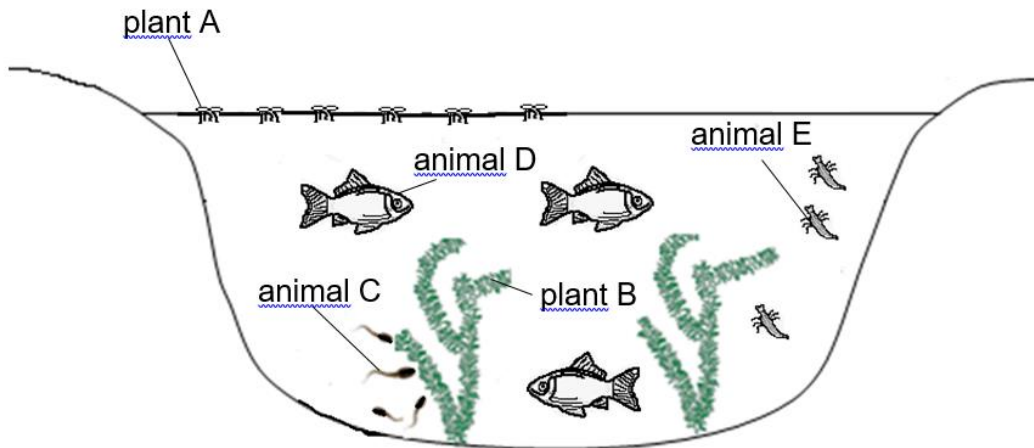
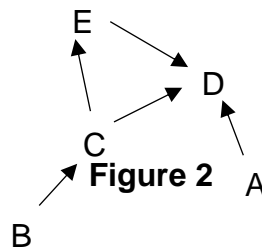

Figure 1

Figure 2 shows a food web in the pond community.



(a) Suggest two benefits that plant B could provide for animal C. [2]

(b) There was a sudden increase in the number of plant A in the pond that they covered the whole pond. How would the population of plant B change? Explain. [2]

Effect on plant : _____

Reason : _____

SCORE	4
-------	---

The graph below shows the oxygen level in the pond when most of plant B start to die and rot.

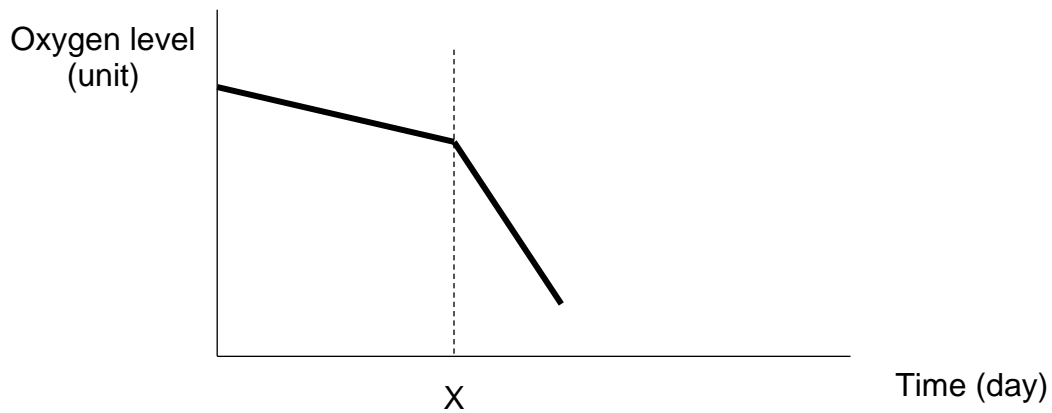

- (c) The oxygen level in the pond decreases sharply after X days. Explain why there is a sharp decrease in the oxygen level. [1]

34. Jerome set up an experiment in a dark room as shown below.

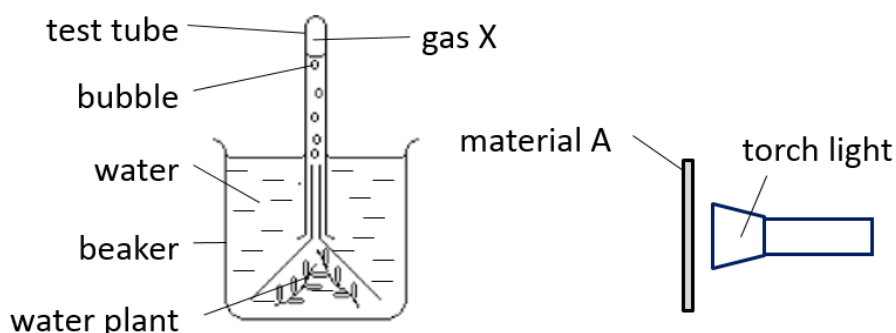

He turned the torch light on and counted the number of bubbles produced by the water plant in 5 minutes. He then repeated the experiment with materials B and C. The table below shows his results.

Material	Number of bubbles produced
A	20
B	0
C	50

(a) Why did Jerome set up the experiment in a dark room? [1]

(b) What is gas X? [1]

(c) Based on his results, which material, A, B or C allows most light to pass through? Explain your answer. [2]

- (d) Jerome repeated the experiment by adding some water snails into the beaker. He observed that the number of bubbles formed increased.

Suggest a reason for his observation.

[1]

35. (a) State a difference between evaporation and condensation.

[1]

Susan is having fever. Her mother dampened a piece of cloth with warm water, and placed the damp cloth on her forehead.

After a while, the damp cloth dried up, and Susan felt that her forehead was much cooler.

- (b) Explain how the damp cloth helped to cool down her forehead even though warm water was used to dampen the cloth?

[1]

36. Andy has a fully inflated toy ball with a volume of 1000 cm^3 . He found that he was able to use a syringe to pump in another 10 cm^3 of air as shown in the diagram below.



- (a) State the volume of the ball after the air is pumped into the ball. [1]

- (b) What does your answer in (a) show about the property of gas? [1]

- (c) Will the mass of the toy ball increase, decrease or stay the same? Give a reason for your answer. [1]

37. Liying added a bulb on her toy train and connected it to some wires, battery and two foil strips to form an electrical circuit. She also build a tunnel and put a strip of aluminum foil inside the tunnel roof. The picture below shows the tunnel and the toy train.

position of aluminum foil
inside the tunnel roof

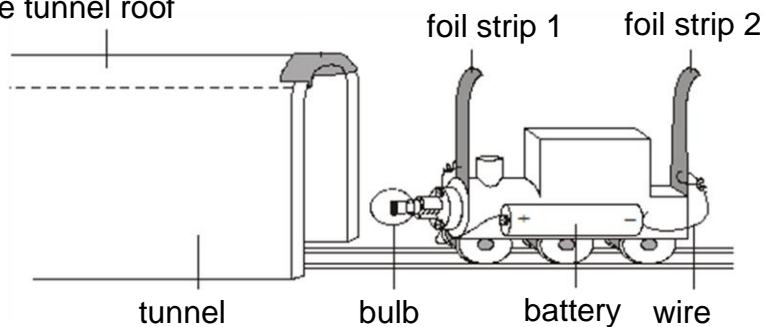

When the train was pushed 15 cm into the tunnel, the bulb lit up.

- (a) Explain why the bulb lit up after the train was pushed 15 cm into the tunnel. [1]

- (b) Liying changed the material of strip 1 to a strip of cardboard and the bulb did not light up. Give a reason for her observation. [1]

- (c) Liying wanted her toy train to light up when the train was pushed 10 cm into the tunnel. Without adding or removing any item, suggest one way to light the bulb after the toy train was pushed 10 cm into the tunnel. [1]

SCORE	1
-------	---

38. Devi glued two magnets, A and B to identical plastic containers. She stacked the two containers and observed that magnet A stayed above magnet B as shown below.

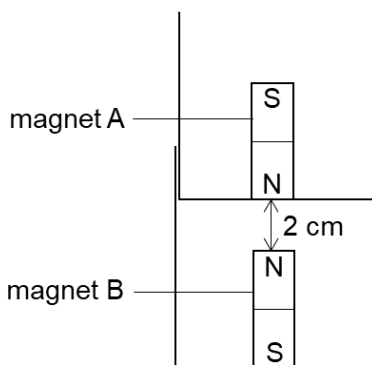

- (a) Devi repeated a few times and magnet A always stayed 2 cm above magnet B. Explain why magnet A stayed above magnet B. [1]

Devi then glued magnet C to a plastic container and placed it above magnet B. She observed that magnet C stayed 3 cm above magnet B as shown below.

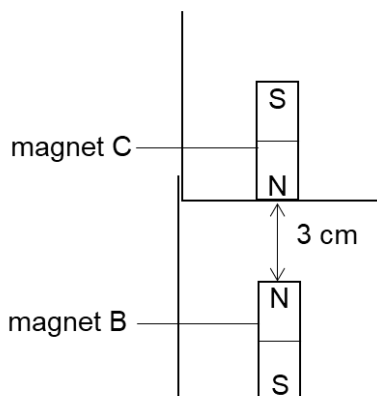

- (b) Based on her observations, what can she infer about the magnetic strength of C? Explain your answer. [2]

Devi then glued an unknown object D to a plastic container before stacking it above magnet B. Her observation is shown below.

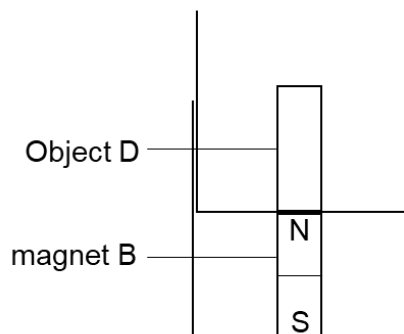

(c) Using only object D and magnet B in their plastic containers, describe how Devi can prove that object D is a magnet. [2]

SCORE	2
-------	---

39. Afiq wanted to find out how the thickness of the wall of a container affects the temperature of cold water in the container. The wall of the container has tiny air spaces which trap air. He used three containers, W, X, Y, and poured the same volume of cold water into each container.

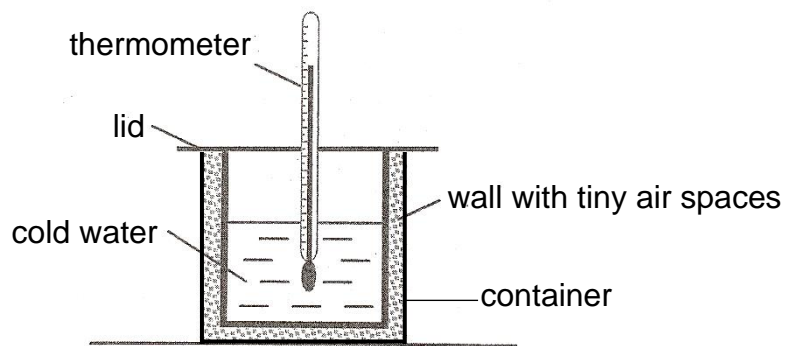

He recorded the temperature of the water at the start of experiment and after 30 minutes.

Container	Thickness of wall (cm)	Temperature of water (°C)	
		Start	End
W	1	10	25
X	2	10	18
Y	3	10	12

(a) How does pouring equal volume of cold water into the three containers make it a fair test? [1]

(b) Based on the results, which container did the water gain heat the slowest? Explain your answer. [1]

Afiq discovered that houses in cold countries usually have windows with two layers of glass, which traps a layer of air in between them, as shown in the diagram below.

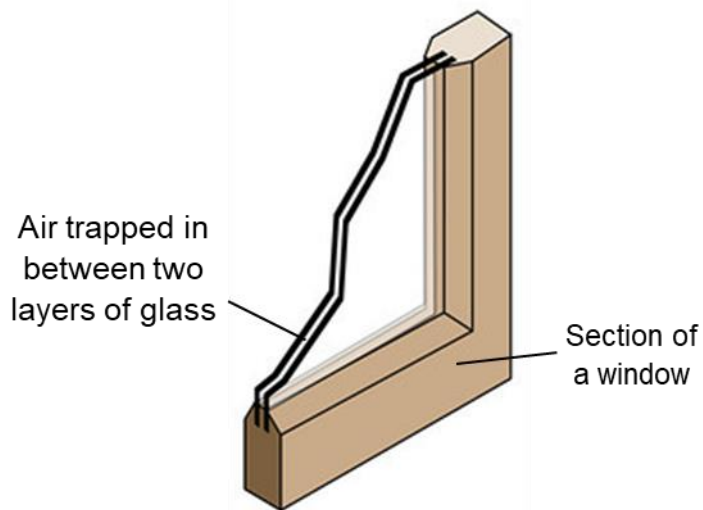

- (c) Based on Afiq's results, explain how having a wider gap between the glass layers helps to keep temperature inside the room higher than outside for a longer period of time. [2]

40. The diagram below shows how a train works with the help of steam. Water is heated in the boiler to produce steam. *Steam* from the boiler goes into the cylinder, causing the piston to move. As the piston moves, the wheels attached to the rod start to move.

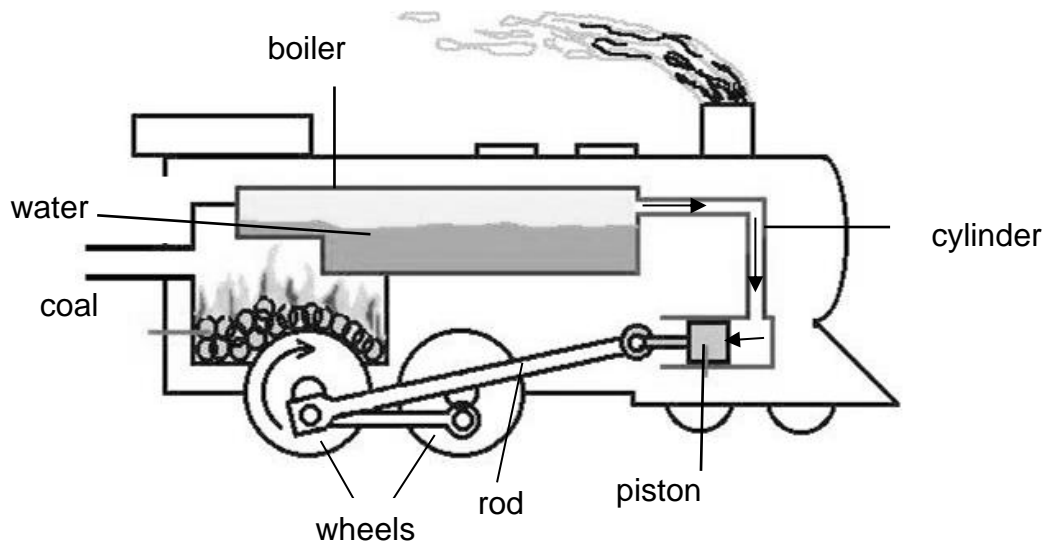

- (a) What is the source of energy for the above train? [1]

- (b) Complete the main energy conversion of the moving steam train. [2]

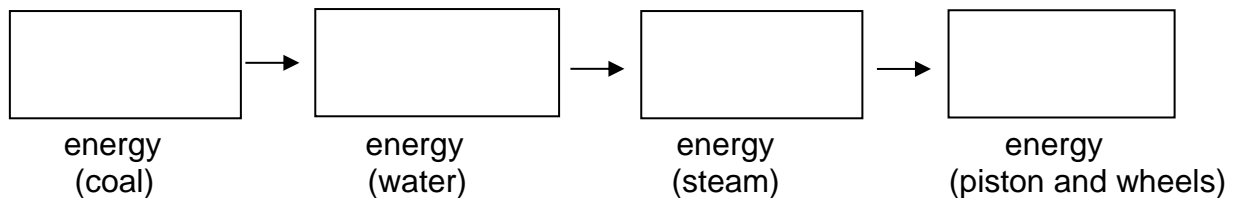

- (c) Explain clearly how the burning of coal leads to global warming. [1]

~ END OF PAPER ~